

M2044 TS / M2048 TS

CNC Servo Motor Driven Ram Turret Punch Press

Turret Layout

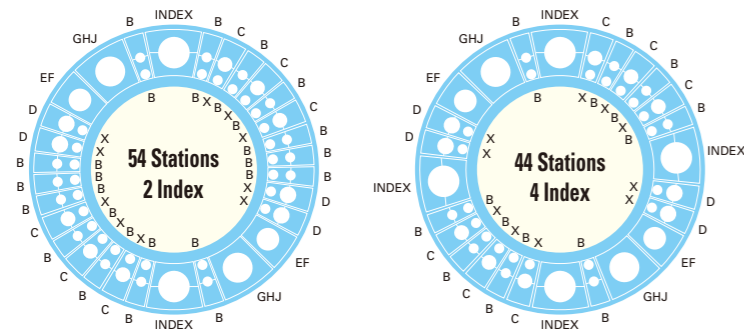

Tooling Range

Range	Round punch	No. of stations	
		54ST/2 Index	44ST/4 Index
X	~12.7 mm [0.5"]	10	10
B	~25.0 mm [1.0"]	28	16
C	~38.0 mm [1.5"]	6	6
D	~50.0 mm [2.0"]	4	4
E	~64.0 mm [2.5"]	2	2
F	~75.0 mm [3.0"]		
G	~89.0 mm [3.5"]	2	2
H	~105.0 mm [4.0"]		
J	~120.0 mm [4.7"]	2	4
INDEX	~75.0 mm [3.0"]		
M/T	12 Stations	2	4
M/K	20,40 Characters		

* With Auto-index stations, Index tool (I/T), Varitool (VT) or Varimark (VM) can be selected as options in desired combination.

Floor Plan

Floor space M2044TS: 2650 mm × 4300 mm [8'8" × 14'1"]
M2048TS: 5150 mm × 4300 mm [16'10" × 14'1"]
Height 2210 mm [7'3"]
Weight 12 tons (11 tons) [26455 lbs (24250 lbs)]

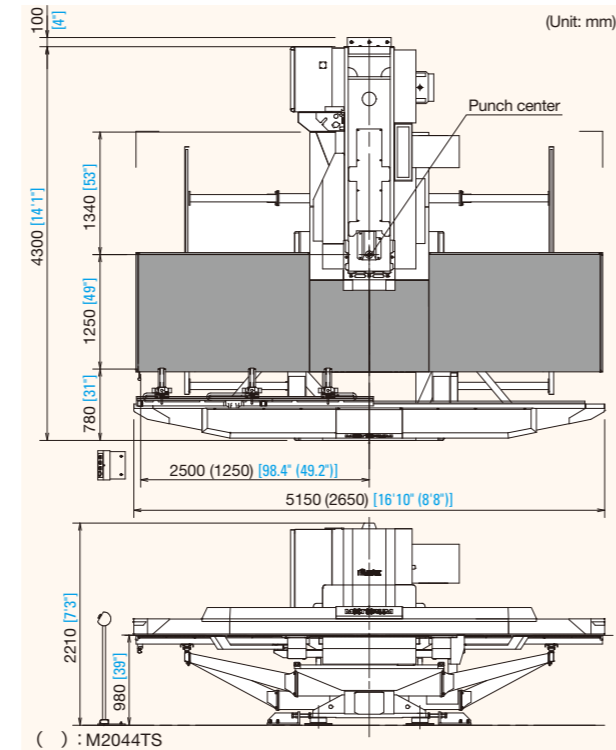

Specifications

	M2044TS	M2048TS
Punching capacity	200 kN (20.4 metric tons) [22.4 US tons]	
Maximum sheet thickness	6.35 mm [0.25"] (Steel ball table)	
Y-axis stroke	1360 mm [53.54"]	
X-axis stroke	1300 mm [51.18"]	2550 mm [100.4"]
Maximum sheet size (YxX)	Without repositioning	1250 mm × 1250 mm [49.21" × 49.21"]
	With one reposition	1250 mm × 2500 mm [49.21" × 98.43"]
Throat depth	1340 mm [53"]	
Maximum allowable sheet weight	75 kg [138 lbs]	150 kg [330 lbs]
Hit rate 1.0t	25 mm pitch 8.3 mm stroke	355 hpm
	0.5 mm pitch 1.4 mm stroke	900 hpm
Simultaneous axis speed	125 m/min [4920"/min]	
Punching accuracy	±0.1 mm [0.004"]	
Turret index speed	35 rpm	
Compressed air	Quantity	100 NL/min
	Pressure	0.5 MPa [71 PSI]
Power supply	19 kVA	

Option

- Retractable forming die function
- Downward form protection
- Tapping unit
- Varitool
- Varimark
- Spring style tooling
- Deburring tool control
- Slug suction unit
- Programmable positioning work holder
- Cell ready

* The machines shown in the catalogue include some optional items and may vary in appearance from the actual machines.
* Specifications and designs are subject to change without prior notice.



MOTORUM SERIES

M2044 TS / M2048 TS

CNC Servo Motor Driven Ram Turret Punch Press



MURATA MACHINERY, LTD. MACHINE TOOLS DIVISION

International Business Dept.
2, Nakajima, Hashizume, Inuyama-shi, AICHI 484-8502, JAPAN
TEL: +81-(0)568-61-3645 FAX: +81-(0)568-61-6455

Headquarters
136, Takeda-Mukaihiro-cho, Fushimi-ku, KYOTO 612-8686, JAPAN
TEL: +81-(0)75-672-8138 FAX: +81-(0)75-672-8691
https://www.muratec.co.jp

MURATA MACHINERY USA, INC
2120 Queen City Drive, P.O.Box 667609, Charlotte, N.C. 28208, U.S.A.
TEL: +1-704-875-9280 FAX: +1-704-392-6541
https://www.muratec-usa.com

MURATA DO BRASIL, LTDA.
Estrada de Santa Isabel, 3383-KM 38,5,
Itaquaquecetuba-SP-CEP 08599-000, BRASIL
TEL: +55 (0)11-4648-6222 FAX: +55 (0)11-4648-6737
http://www.muratec.com.br
e-mail: muratec@muratec.com.br



MURATA MACHINERY EUROPE GmbH
Hanns-Martin-Schleyer-Strasse 3, D-47877, Willich, GERMANY
TEL: +49-(0)2154-914-250 FAX: +49-(0)2154-914-283
e-mail: info@muratec.de

MURATA MACHINERY (SHANGHAI) CO.,LTD
[Registry Add]
135 Fu Te Xi Yi Rd., Wai Gao Qiao Free Trade Zone,
Pudong, Shanghai, CHINA
[Contact Add]
150 Xin Gao Rd., Qingpu Industrial Zone,
Shanghai, 201700, CHINA
TEL: +86-(0)21-6921-2300 FAX: +86-(0)21-6921-2331
BEIJING BRANCH
Rm. 309 Yu Lin Bldg., Xiang Jun Nan Li Er Xiang Jia No.5,
Chaoyang-qu, Beijing, 100020, CHINA
TEL: +86-(0)10-6597-3048 FAX: +86-(0)10-6591-1795
GUANGZHOU BRANCH
Room 635, United Star Hotel, 172 Chang Gang Rd., C.,
Guangzhou, 510250, CHINA
TEL: +86-(0)20-8434-2882 FAX: +86-(0)20-8434-3463

MURATA (THAILAND) CO., LTD.
898/43-44 SV CITY TOWER 2,25th Floor, Rama 3 Road
Bangpompang, Yannawa,Bangkok 10120, THAILAND
TEL: +66-(0)2294-7734-40 FAX: +66-(0)2294-7732

PT.MURATA MACHINERY INDONESIA
Ruko Gyan Plaza D-4, Jl.Terusan Pasirkoja Blok 8,Bandung
40222, INDONESIA
TEL: +62-(0)22-6046633 FAX: +62-(0)22-6046612

MEIBAN ENGINEERING TECHNOLOGIES PVT.LTD.
[An associate company of Murata Machinery, Ltd.]
No 38, 7th Main, J.C. Industrial Estate, Yelachanahalli, Kanakapura Road,
Bangalore -560 062 INDIA
TEL: +91-(0)80-2686-0600 Fax: +91- (0)80-2686-0605
http://www.meibanengg.com
e-mail: office@meibanengg.com

M2044 TS / M2048 TS

Servo Drive Pioneer Motorum has evolved to a new level

CNC Servo Motor Driven Ram Turret Punch Press

Muratec introduced world's first servo driven punch press in 1994. Since then we our industry leading technology has evolved to meet the next generations needs. Here is the latest in our award winning Motorum series!



Note: Photographs in this catalogue include some options.

Utilization!
Compactness!
Functionality!



Muratec has been contributing to protect environment by producing ECO friendly machine. M2044TS/M2048TS has been certified MF Eco machine admitted by Japan Forming Machinery Association.

New Drive Ram Mechanism

The ram drive of M2044TS/M2048TS series has incorporated CFRP in the part of toggle mechanism connected directly to the servomotor making it lighter in weight and more rigid. The new drive mechanism and the replacement of the alternating movement decreases vibration by 65%. In addition, a reduction of motor heat saves energy in cooling and the recovery of electric energy when braking.

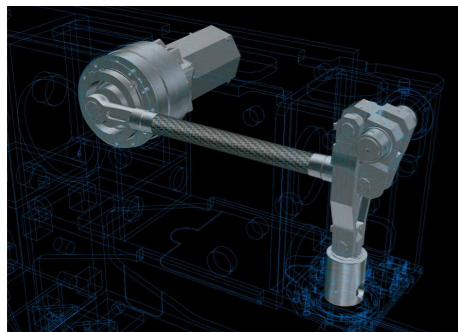

Ram Operation Patterns

The servo motor drive mechanism delivers precise RAM control. Combined with Muratec application, M2044TS/M2048TS enables Ram Operation Patterns ideal for a wide range of processes.

High speed punching:



The servo motor is driven alternately between hover height and bottom dead center with a back and forth motion. The hover height position is adjusted based on material type and thickness. This control of the ram stroke provides high speed punching and efficient productivity.

Forming Operation:

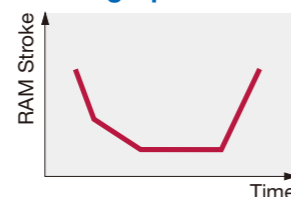

Using variable servo motor control ram stroke between top dead center and bottom dead center, the best results and excellent performance in forming tool operation can be achieved. An important benefit of controlling the ram stroke is to specify a dwell time at bottom dead center and allow material flow during the forming operation.

Low noise operation:

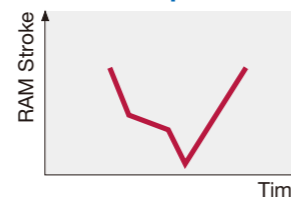

Full control of the ram speed within one punching cycle achieves the ultimate reduction in noise and vibration.

Noise / Vibration Data

The new drive system reduces both noise and floor vibration while punching in comparison to previous model.

Tonnage: 200 kN

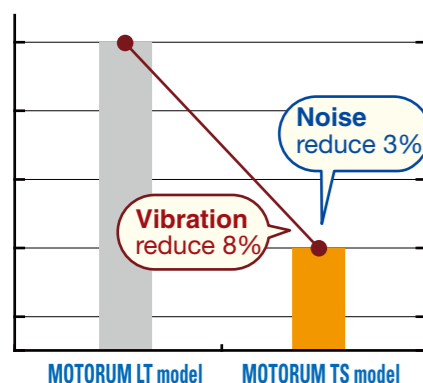

Time Study

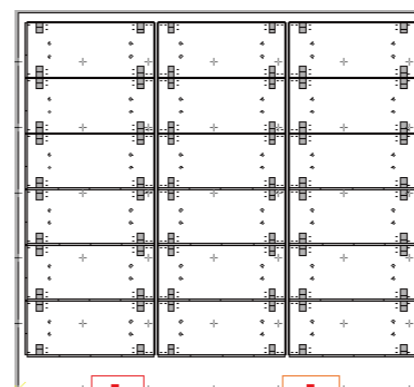
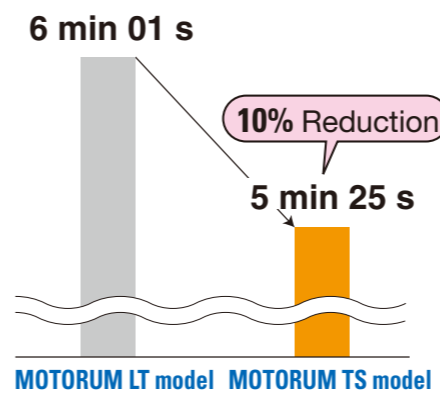

Worksheet example (SPCC/1.2 t)
Material size: X1250mm × Y1000mm
Number of tools: 6
Total hits: 660

Punch-in, Pull-Out Type Wiedemann Tooling

The positive Punch-in and Pull-out design of the ram, which is mechanically linked to the punch holder during the punching cycle, guarantees positive punching. This design has already been field proven for its high strength, precision and simplicity of tooling. By combining this feature with the newly innovated servo motor driven ram, the reliability of the machine has been greatly enhanced.

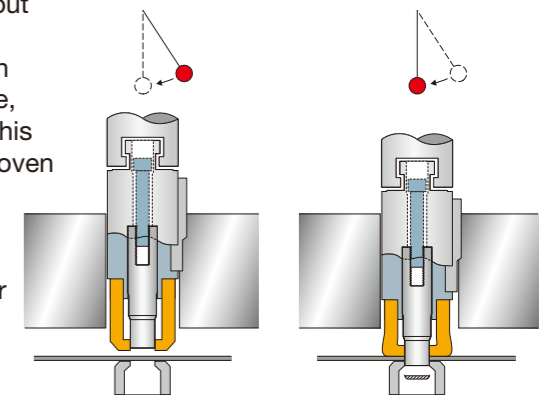

Energy Conservation & Low Running Cost

An environmentally friendly eco-machine, the Motorum servo motor drive mechanism uses energy only at the time of punching.

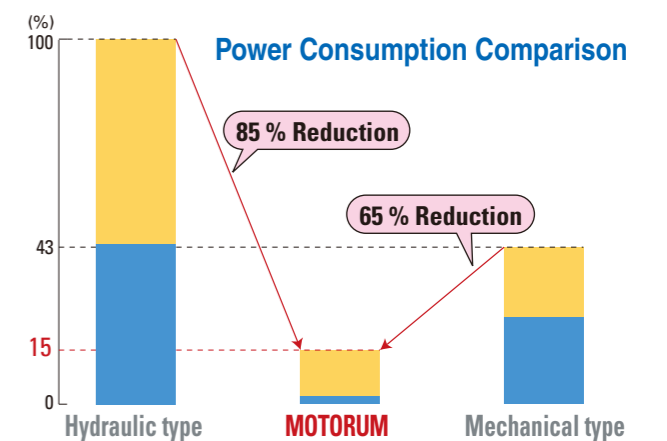

The Key to Better Processing

M2044TS/M2048TS provides high speed processing with reliability and accuracy. This machine also raises overall productivity through process integration of deburring, forming, tapping and other processes, together with reduction of time needed to setup and program.

High-speed Marking Mode

By using the high-speed marking mode, marks are made in the material for easy product identification for next process in little time.

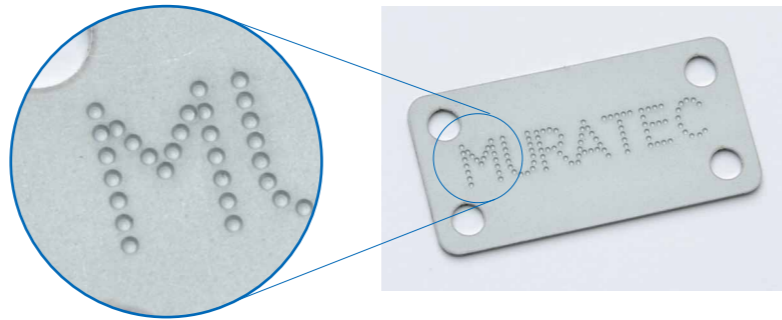

Forming

Optimum control of RAM speed leads to fast and accurate forming of the highest quality, with minimal distortion of the workpiece.

Retractable forming die function Option

Upward forming tool dies are retracted to die height when not in use. This is to avoid interference of the forming die with the workpiece and workholders. This allows free movement of the sheet without any restrictions and improves quality.

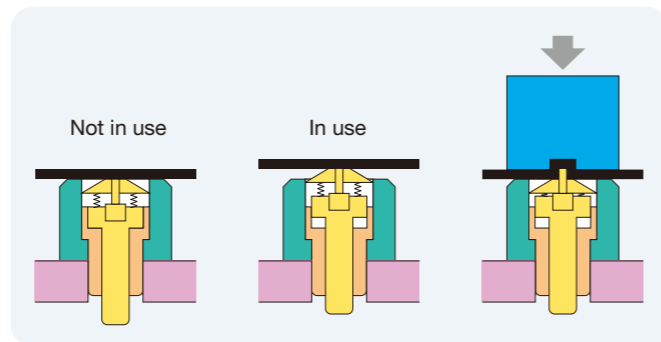

Downward form protection Option

Conventional turret punch presses have long had difficulty with downward extrusion. As the formed work is lifted off the upper surface of the die during table/sheet movement, this option eliminates degradation of the form stemming from interference with the die.

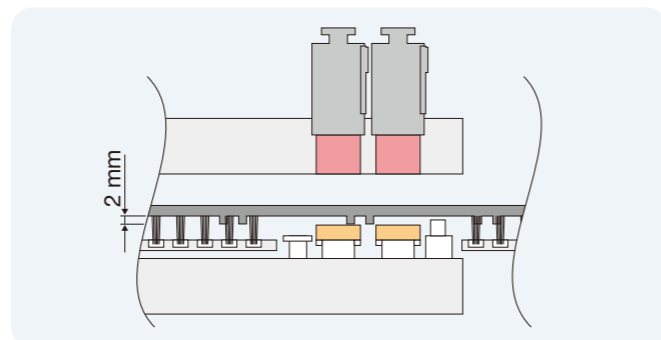

Tapping Units Option

A full-scale rigid tapping unit using with synchronization of RPM and feed speed by the servo motor.

- Tap size: M2 ~ M10
- Tapping methods: Machine thread / Rolling thread
- Max. sheet thickness: 6.35 mm [0.25"]

*Specifications vary, depending on type of material, hole diameter, etc.

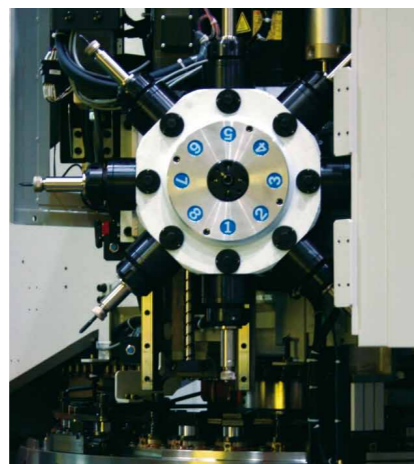

8-Station Tapping Unit (Option)

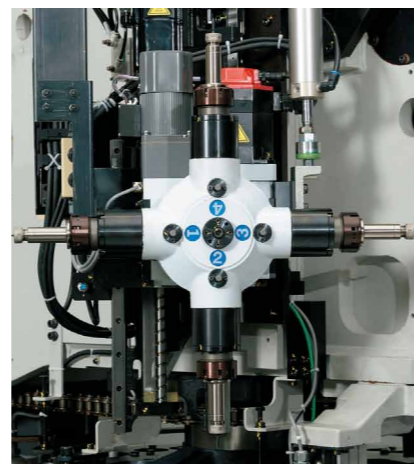

4-Station Tapping Unit (Option)

Deburring operation Option

One tooling. All round deburring operation

Deburring and pinching operation using the ball bearing manufactured originally by Muratec. Two bearings from top and bottom sides removes the burr of the edge both sides, upper and lower, of the punched parts simultaneously by pinching the edge of the punched sheet along with the path.

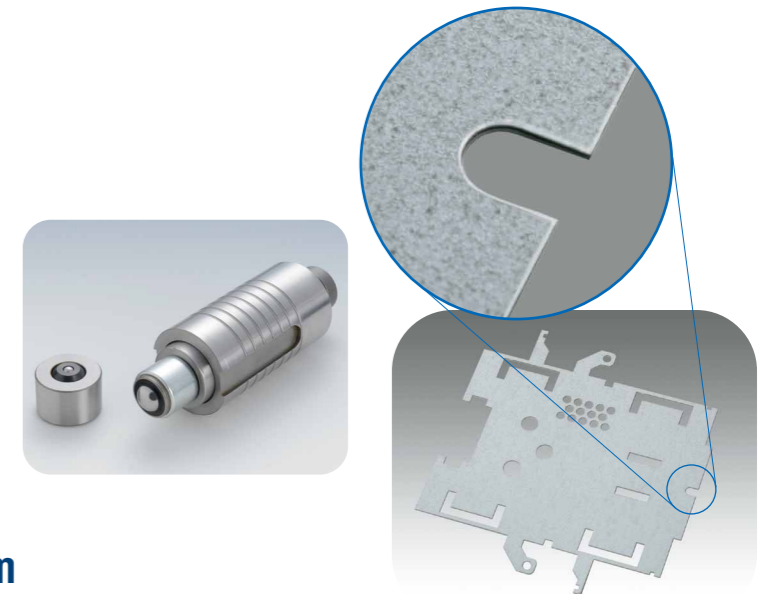

High-Speed Auto-Index Mechanism

Index tool speed has been raised to 100 rpm. Reduction of positioning time for index tool angles, multi-tools and marking tools shortens production time.

High-Speed Indexing

Fast indexing at any angle shortens production time for complex forms.

Varitool Option

The Varitool is available in 12 tool configurations. Using Varitool in the Auto-index station increases the turret tool capacity. The 12-station tool configuration has tool sizes up to 12.7 mm dia.



Varitool
12-station type

Varimark Option

The Varimark is built-in with 20 or 40 standard alphanumeric and punctuation characters for stamping on the worksheet.



Varimark
Stamping Character Size:
2.1 mm x 3.2 mm (40 characters)
[0.08" x 0.13"]
3.2 mm x 5.0 mm (20 characters)
[0.13" x 0.20"]

Wilson Wheel Option



Rolling Offset

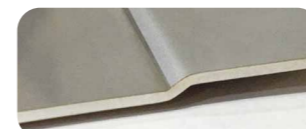

Rolling Rib

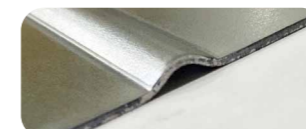

Mate Precision Tooling Option



Sheet Marker



Roller Ball

Rigid Press Frame

Improved stability in the punching process using 12.5% thicker material for the press side frames and improved stiffness of base component.

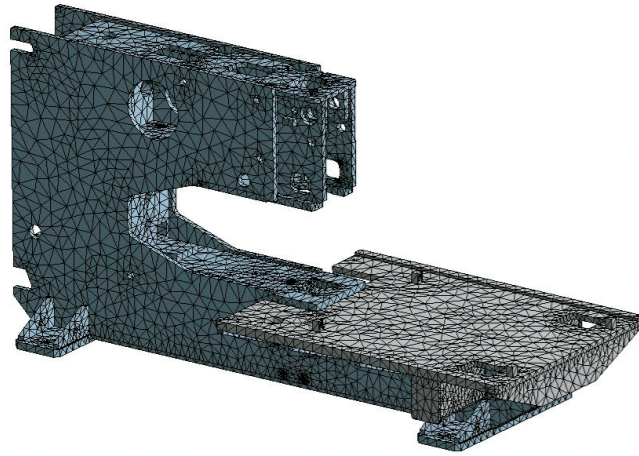

Designed for higher productivity, quality and operating ease

Brush Table

While reducing scratching on the back of the worksheet, the brush table also gives stable movement of the worksheet. The brush table reduces noise during worksheet movement and eliminates scratches to the back of worksheet.

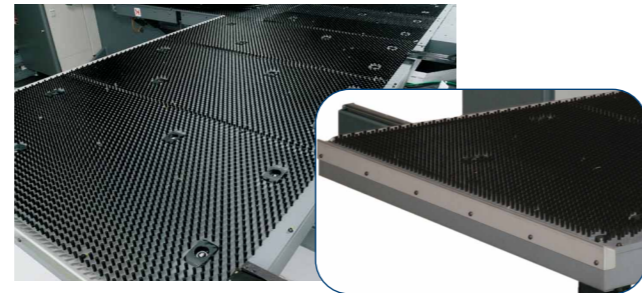
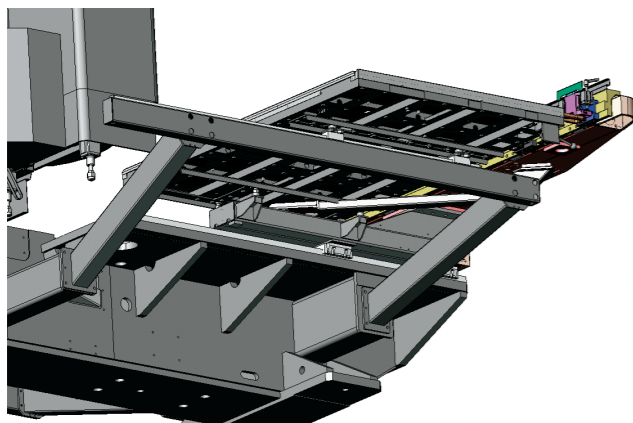

Table Structure

Improved stability in table motion by utilizing a two point LM guide support for high speed processing. In addition, ball screws are now used for the X and Y axes providing improved maintenance.



Retractable Repositioning Pad Buttons

Retractable repositioning pad buttons are raised automatically for clamping the worksheet during the repositioning operation only. During normal punching when the worksheet is moving over the repositioning pad buttons, the buttons are retracted downward which eliminates scratches on the under side of the worksheet. This enhances the quality of the finished worksheet.

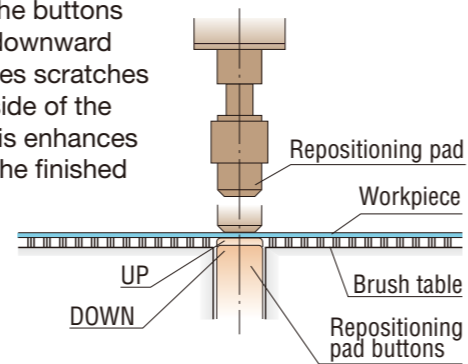

Slug Suction Unit Option

The slug suction unit enables better punching quality and minimizes slug pull-back problem for thin worksheets. This function is extremely useful while processing worksheets having scratch prevention films. The air suction helps to detach cut films from the workpiece.

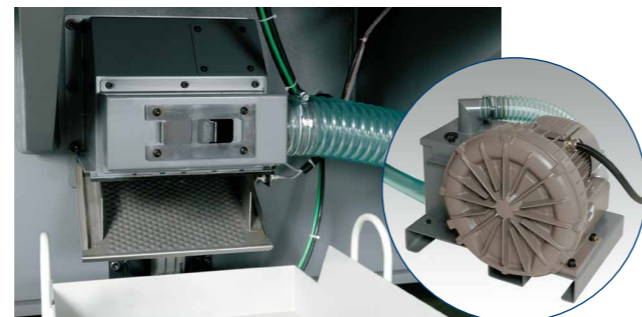

Crash Sensor

Prevent major damage to the machine. Crash sensors stop the machine when material curves upward toward the turret preventing a collision.



Scheduling Function

Scheduled job production guides the operator on a standalone machine. Program NC and scheduling data is automatically downloaded to the machine. Required tooling, material and work holder setup information is also displayed.

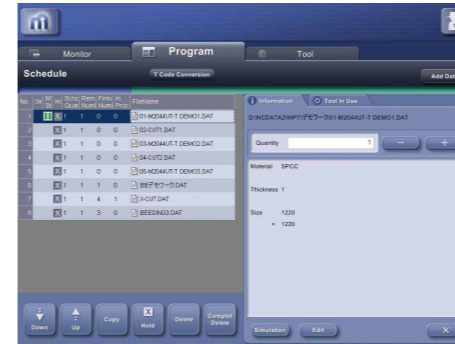

Expanded Processing Condition List

The processing modes of 1000 tool types with 5 pattern setups can be registered for 30 material types and thicknesses. This allows for setting the detailed processing conditions of all the customer's tooling.



Processing Simulation Function *

The current processing position during machine operation is displayed in red. This allows recognition at a glance of the punching sequence and production progress.

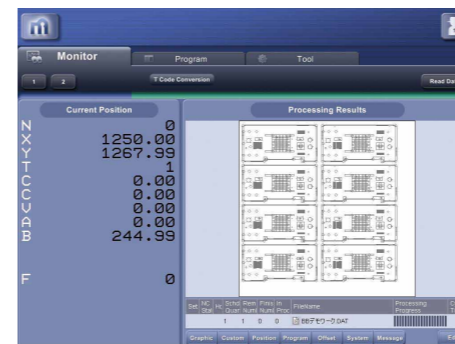

Tool Management *

A library of all the machine tooling is maintained on the control. The hit counts for all tools and dies are then tracked to allow scheduled maintenance when the hit counts exceed the predetermined maximum count.



Machine Control Functions

Various utilities are available to the operator. Optional log files can be viewed for machine operation and program start/finish times. Also machine alarm history can be viewed.



Turret Monitor Function *

Displays information on current tooling set in the turret. This allows tooling in scheduled jobs to be analyzed and it automatically determines when tool changes are required.



*Above function requires Muratec original program format.